

Read the General Rules in the manuals and on www.soinc.org as they apply to every event.

1. **DESCRIPTION.** Participants will use remote sensing imagery, science and mathematical process skills to complete tasks related to an understanding of the **Earth's Hydrosphere.**

A TEAM OF UP TO: 2

IMPOUND: No

APPROXIMATE TIME: 50 Minutes

2. **EVENT PARAMETERS:** Each team may bring five 8.5" x 11" two-sided sheets of paper containing any information from any source. Each participant may bring a metric ruler, a protractor, a triangle, a **magnifying glass**, and any kind of (non-graphing) calculator, but no other resources.
3. **THE COMPETITION:** Students should understand concepts and terms related to how remote sensing technologies are used to record data and monitor changes in the atmosphere and hydrosphere using measurements of:

- Atmospheric temperature and temperatures of oceans, inland seas and bodies of fresh water
- Greenhouse gases in the atmosphere including water vapor, carbon dioxide, methane and nitrous oxide
- Changes in vegetative cover
- Changes in sea level and ice elevation
- Other changes in geological, hydrological and in man-made features associated with bodies of water portrayed on a remote sensing image
- Students should also be familiar with principles of satellite imagery including the electromagnetic spectrum, interactions between electromagnetic energy and the atmosphere/hydrosphere, and NASA Earth Observation Missions related to monitoring of the atmosphere/hydrosphere.

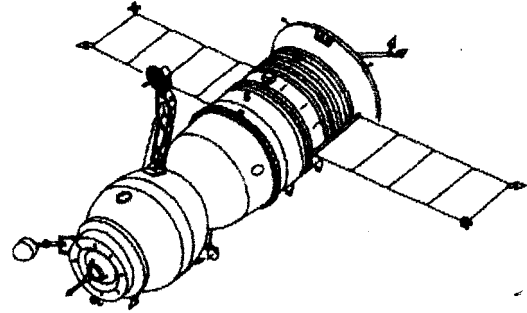

4. **SAMPLE ACTIVITIES:**

- Compare a remote sensing image of a glacier with a similar image acquired earlier to determine changes in the area and depth of ice that have taken place in the elapsed time.
 - Use a remote sensing image to evaluate damage to residential land use and transportation infrastructure caused by flooding or reservoir impoundments.
 - Use time-lapsed remote sensing imagery to track the path of an oil spill and predict its effect on local wetland regions
5. **SCORING:** Teams with the highest number of correct responses will be the winners. Selected questions or question sets may be used as Tiebreakers.

Recommended Resources: All reference and training resources including the **Remote Sensing CD** are available on the Official Science Olympiad Store or Website at <http://www.soinc.org> and the *Laboratory Manual in Physical Geology* Eighth Edition 2009 AGI/NAGT.

* should know differences between infra red and true color
 * if you would like a CD with study guides/tutorial created by Dick Filson let Annie know.